

## Содержание

ATX .....	3
-----------	---

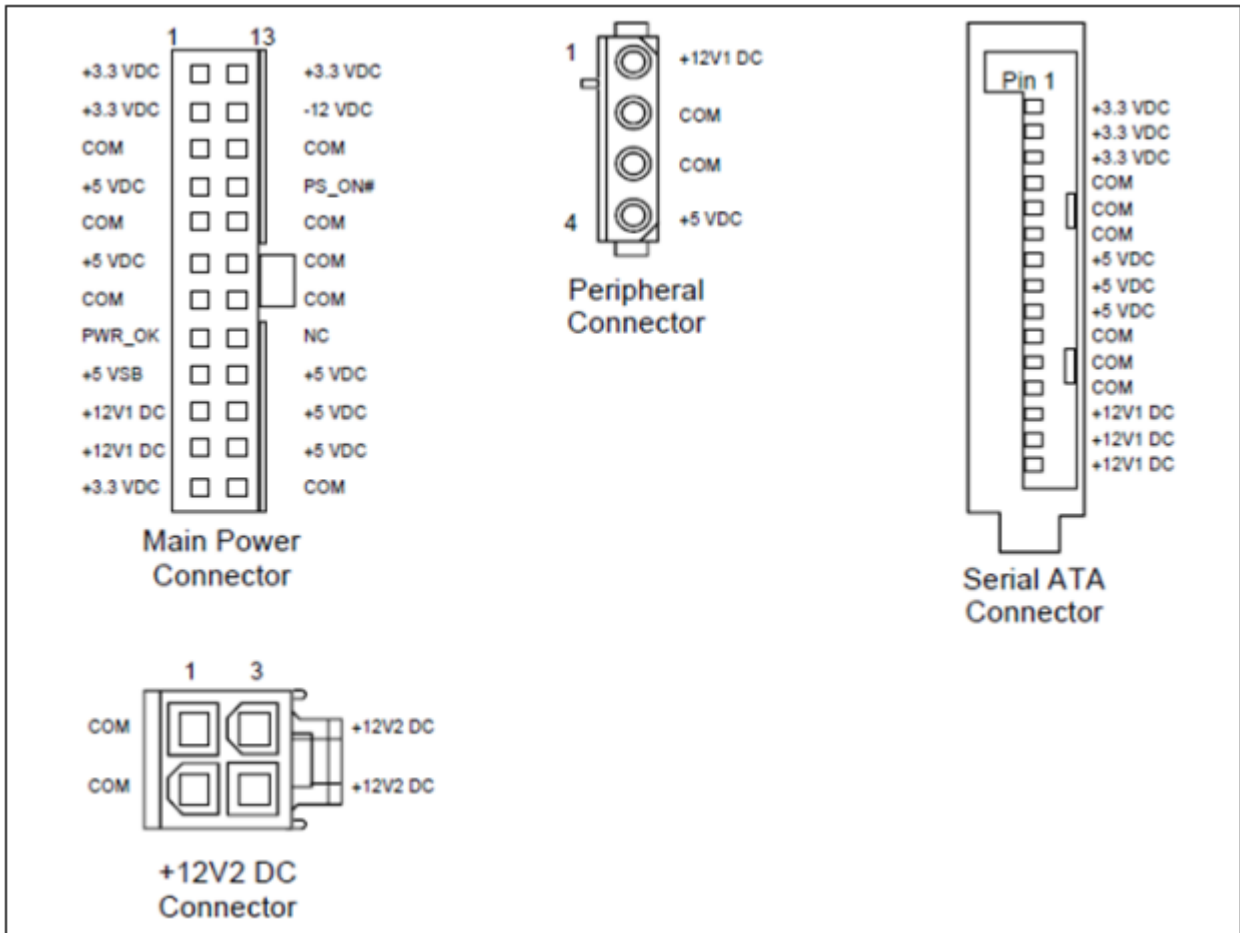

# ATX



link	ext	description	manufacturer	version	date	lang
<a href="#">atx_2_2.pdf</a>	pdf	ATX Specification Version 2.2	Intel	2.2	2004	EN
<a href="#">atx_201.pdf</a>	pdf	ATX Specification Version 2.01	Intel	2.01	1997	EN
<a href="#">power-supply-design-guide-june.pdf</a>	pdf	Desktop Platform Form Factors Power Supply Design Guide June 2018 Revision 002	Intel	002	2018.06	EN

**R1A-KH0400:**

Load	+3.3V	+5V	+12V	-12V	+5Vsb	EFF
20%	2.4A	2.4A	4.77A	0.07A	0.4A	>84%
50%	6A	6A	11.91A	0.15A	1.0A	>89%
100%	12A	12A	23.82A	0.3A	2.0A	>88%

YH-5301E:

OUTPUT	NOM VOLT	OUTPUT CURRENT			UNITS	CONDITION
		MIN	MAX	Peak		
1	+3.3V	0	20 #a	24	A	combined #a & #b power ≤ 140W
2	+5V	0	20 #b	24	A	
3	+12V	0	24	31.7	A	
4	-12V	0	0.5	N/A	A	
5	+5V <sub>sb</sub>	0	3	4	A	

YM-2301E:

Output Wattage		+12V			+5Vsb		
Max.	Peak	Minimum	Maximum	Peak	Minimum	Maximum	Peak
300W		0A	24A	31.7A	0A	3A	4A
Total output power			288W	380.4W		15W	20W

link	ext	description	manufacturer	version	date	lang
<a href="#">R1A-KH0300.pdf</a>	pdf	<b>R1A-KH0300</b> Datasheet ASPOWER Electrical Specification	ASPOWER	S0	2020.05.06	EN
<a href="#">R1A-KH0400.pdf</a>	pdf	<b>R1A-KH0400</b> Datasheet ASPOWER Electrical Specification	ASPOWER	S0	2020.05.06	EN
<a href="#">YH5301-1EAR - Spec new.pdf</a>	pdf	<b>URP1X-300 (YH-5301E)</b> Datasheet Power Distribution Board Specification URP1X 300W DC-DC Switching Power Distribution Board 80Plus Silver compliant	3Y POWER			EN
<a href="#">YM-2301EA27R Drawing.pdf</a>	pdf	<b>OAD16009632-R2</b> Drawing and pinout Released Date:2018/11/09-10:28:48 YM-2701E,A27R	FSP		2018.11.09	
<a href="#">YM-2301EA27R Spec..pdf</a>	pdf	<b>YM-2301E,A27R</b> Datasheet ESD16008614-R1 Released Date:2018/11/12-11:40:18	3Y POWER			